

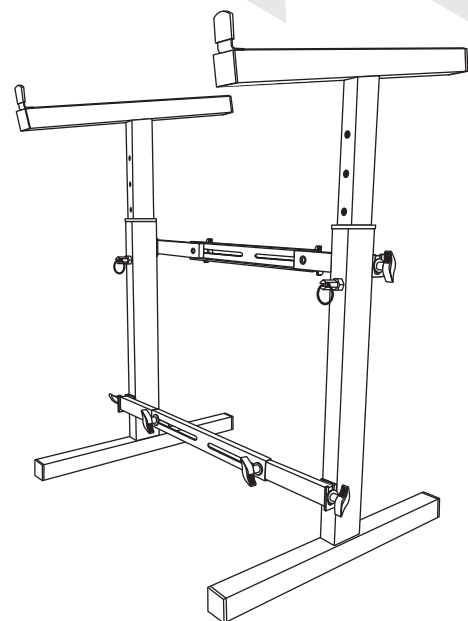

RXS20 ASSEMBLY GUIDE

Thank you for purchasing the RXS20 Heavy Duty Mixer Stand. Please read these instructions carefully before use. Make sure all parts are included. If any parts are missing please contact our technical help line at 1-646-758-0144, Monday through Friday, 9am to 5pm EST. Also you can check out our informational video on YouTube: <https://youtu.be/qgBge1tP4qQ> or search Rockville RXS20.



A		2 pcs.
B		2 pcs.

STEP 1

Begin by taking part B and loosening both extension lock knobs (fig. A). Extend both arms approximately 1 inch (the arms can be extended up to 23.6 inches). Tighten the lock knobs to hold the extension arms in place (fig. B). Do this for both pieces.

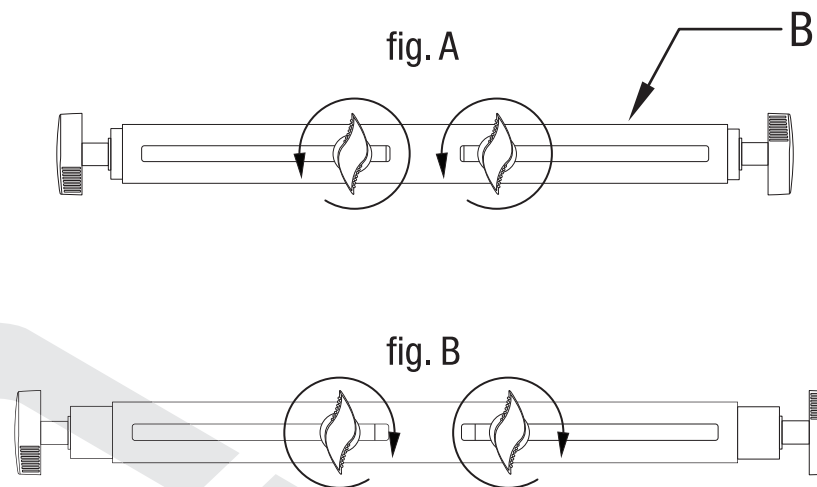

STEP 2

Adjust the height of the stand legs by pulling the retaining pin out (fig. C) and sliding the extension to the desired height (fig. D). Once you've attained the desired height, please make sure that the retaining pin is properly seated. There are 8 positions to choose from, with a maximum height of 36 inches.

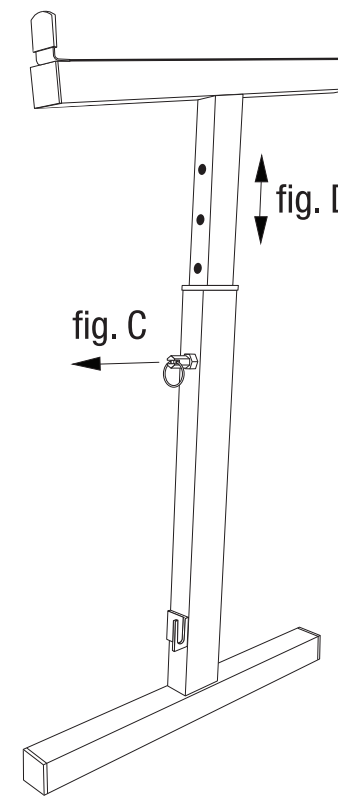

STEP 3

Stand both part A L1 and R1 upright. You may need assistance while performing this step. Loosen both the locking knobs at either end of the extension bar (fig. E). Slide part B onto the top retaining slots as indicated in fig. F. Make sure that the washers are on the outside of the retaining slots (fig. G). Once the extension bar is properly seated, tighten the lock knobs (fig. H).

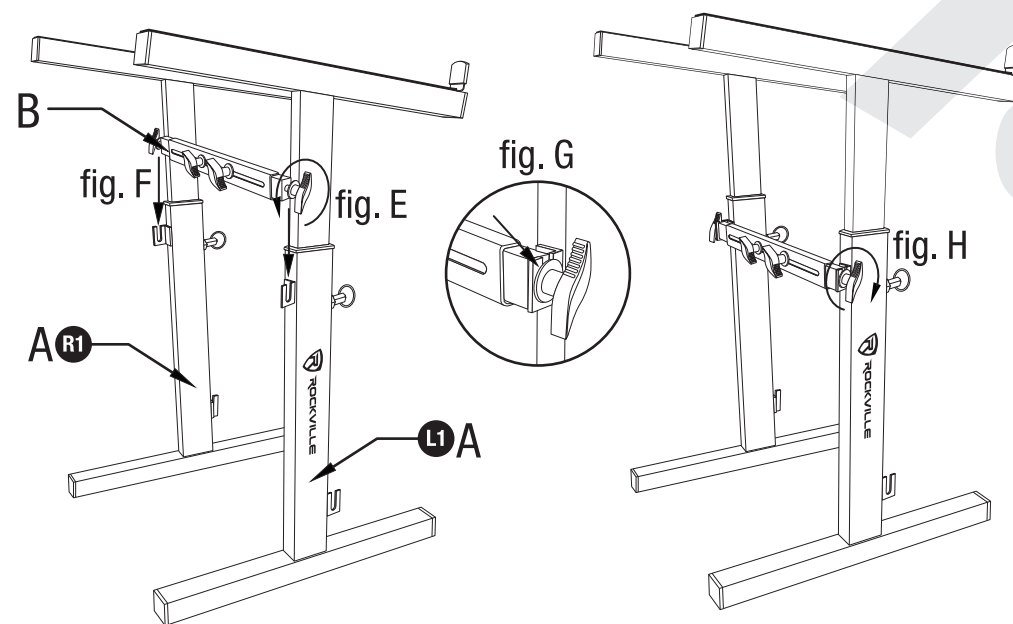

STEP 4

Repeat step 3 to attach the lower extension bar.

