

# ROCKVILLE

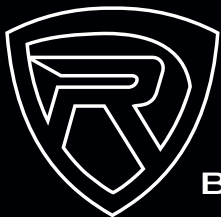

**OWNER'S  
MANUAL**



**BTH5**  
**BLUETOOTH HEADPHONES**

Thank you for purchasing these Rockville BTH5 Bluetooth Headphones. The elegant design and functionality of these headphones will surely make them your favorites whether you are on the go or relaxing at home. They provide hours of high quality audio playback and also offer the convenience of hands-free calling.

Please read this installation guide carefully for proper use of your Rockville BTH5 Bluetooth Headphones. Should you need technical assistance please call our technical help line at 1-646-758-0144, Monday through Friday, 9am to 5pm EST.

## **FEATURES**

- Bluetooth Headphones With Incredible Bass and Clear Highs
- Bluetooth Version 4.1 connects quickly with a 33 foot range
- 25-hours music playback at medium volume
- Charge time: 2 hours
- 40mm drivers x2
- Large over-the-ear cups with the thickest and most comfortable cushion in the industry
- Built-in microphone for hands free calling
- Ear cup buttons offer easy controls for music and calls
- Positive Sound Cancellation
- Incredible bass response
- Crystal clear highs
- Minimal bleed
- Soft and comfortable headband
- Ear cups rotate and fold for compact storage
- Detachable 31.5" coil
- Cable is made of 100% Oxygen Free Copper
- Gold plated 3.5mm connector
- USB charging cable included

## **SPECIFICATIONS**

- Bluetooth Range: 33ft
- Style: Closed-Back
- Design: Circumaural
- Transducer Type: Dynamic
- Driver: 40MM
- Sensitivity: 110±3dB
- Impedance: 32ohm
- Frequency Response: 20Hz – 20KHz
- Net Weight: 400g

## FUNCTIONS

1. **Power/Play-pause:** Press for 5 seconds to power on. Press for 3 seconds to enter pairing mode. Quickly press to play/pause current track.

2. **Volume down:** Press and hold to increase volume. During playback mode quickly press to skip to the previous track.

3. **Volume up:** Press and hold to decrease volume. During playback mode quickly press to skip to the next track.

4. Press once to answer or end a call. Double press to redial last number.

5. Aux-in

6. Bluetooth/charging LED indicator

7. Micro USB charging port

8. Microphone

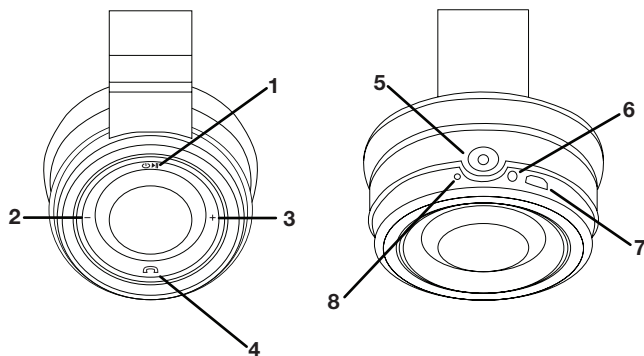

## CHARGING

1. Connect the included micro USB cable to the headphones. Connect the other end to a computer or AC adapter (not included).
2. The LED indicator will turn red during charging.
3. Once the unit is fully charged, the LED indicator will turn off.

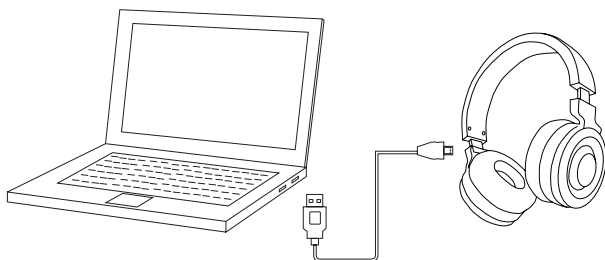

## BLUETOOTH PAIRING

1. Press and hold the power button until you hear a tone and the LED indicator flashes blue and red.
2. Keep your Bluetooth headphones and Bluetooth enabled device within 3 feet of each other during the pairing process.
3. Make sure Bluetooth is active on your device and that it is discoverable.
4. Look for “BTH5” in your list of available devices and select it.
5. If you are asked for a PIN or pass code, enter “0000”.
6. If pairing is successful you will hear a tone and the indicator LED will intermittently flash blue.

**Please note:** In order to pair a new device, you must unpair the currently paired device. After disconnecting, turn the headphones on and off to reenter pairing mode.

## USING AS WIRED HEADPHONES

1. Connect one end of the included 3.5mm cable to the 3.5mm jack on the bottom of the right ear cup.
2. Connect the other end of the cable to your external device's 3.5mm output jack.
3. Use the controls on your external device to control audio playback and volume.

## TROUBLESHOOTING

PROBLEM	SOLUTION
I can pair my headphones to a Bluetooth device but I cannot hear any music.	<ul style="list-style-type: none"><li>• Make sure your device supports the A2DP profile.</li><li>• Turn up the volume on your Bluetooth device.</li><li>• Unpair your headphones and re-pair to the device.</li></ul>
The headphones will not go into pairing mode.	<ul style="list-style-type: none"><li>• Make sure the headphones are off before beginning the pairing process.</li><li>• Press and hold the power button until a tone is heard and the LED indicator light flashes blue and red.</li><li>• Check that the headphones are charged.</li></ul>
My Bluetooth device is unable to pair with the headphones.	<ul style="list-style-type: none"><li>• Make sure the headphones are off before beginning the pairing process.</li><li>• Keep your headphones and Bluetooth enabled device within 3 feet of each other during the pairing process.</li><li>• Check that the devices Bluetooth feature is turned on.</li><li>• Try repeating the pairing process.</li></ul>

# FEDERAL COMMUNICATIONS COMMISSION COMPLIANCE INFORMATION

Responsible party name: Rockville

Address: 600 Bayview Ave,  
Entrance A,  
Inwood, NY 11096

Hereby declares that the product Rockville BTH5 Bluetooth Headphones comply with FCC rules as mentioned in the following paragraph:

This device complies with Part 15 of the FCC rules. Operation is subject to the following two conditions: (1) this device may not cause harmful interference, and (2) this device must accept any interference received, including interference that may cause undesired operation.

Note: This equipment has been tested and found to comply with the limits for a Class B digital device, pursuant to Part 15 of the FCC rules. These limits are designed to provide reasonable protection against harmful interference in a residential installation. This equipment generates, uses and can radiate radio frequency energy and, if not installed and used in accordance with the instructions, may cause harmful interference to radio communications. However, there is no guarantee that interference will not occur in a particular installation. If this equipment does cause harmful interference to radio or television reception, which can be determined by turning the equipment off and on, the user is encouraged to try to correct the interference by one or more of the following measures:

- Reorient or relocate the receiving antenna.
- Increase the separation between the equipment and receiver.
- Connect the equipment into an outlet on a circuit different from that to which the receiver is connected.
- Consult the dealer or an experienced radio/TV technician for help.

***ROCKVILLE***

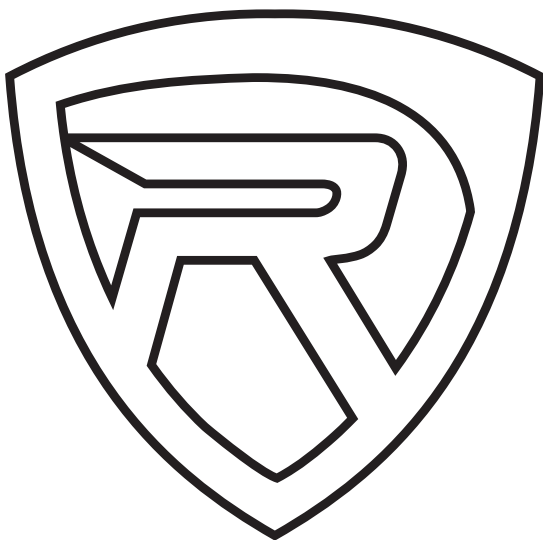

**RockvilleAudio.com**

© 2017 ROCKVILLE // Features and specifications are subject to change and or improvement without notice.