

Included:

- 2x 3" locking caster wheels
- 2x 3" swivel caster wheels
- 16x screws
- 16x t-nuts
- 16x locking washers
- 16x washers
- 1x M8 drill bit

Tools needed:

- Electric Drill
- Hammer
- Pencil or marker
- Drill bit (included)
- Wrench (included)

Instructions:

1. Begin by marking off the mounting location (fig. A). We recommend you mount the casters 1 inch in from either side of the corners of the enclosure (inset).
2. Place the caster wheel within the denoted mounting area and mark the locations of the screw holes (fig. B). Now drill holes where your marks are (fig. C). Do this for all four wheels.
3. Now remove the grill (fig. D) and subwoofer (fig. E) so you can access the inside of the enclosure so the t-nuts can be installed. When removing the subwoofer, be mindful of the cables as there may not be a lot of slack.
4. Insert a t-nut into each hole (fig. F). Use the hammer to ensure that the t-nut is properly seated and secure.
5. Using a screw, locking washer, and washer (fig. G) secure the wheels in place.

fig. A

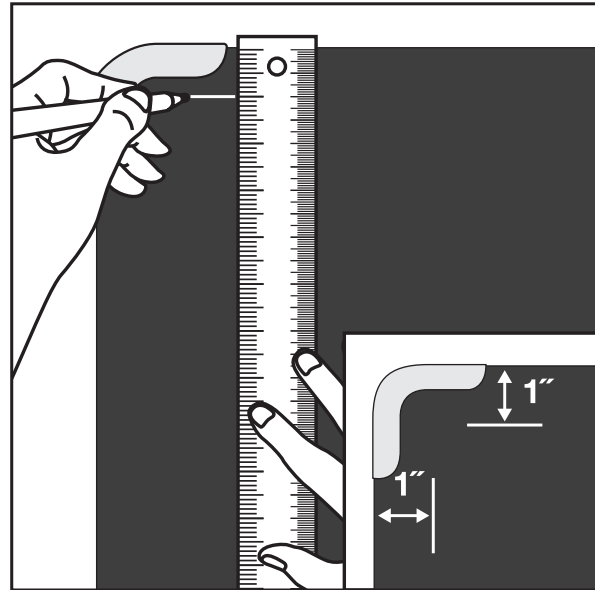

fig. B

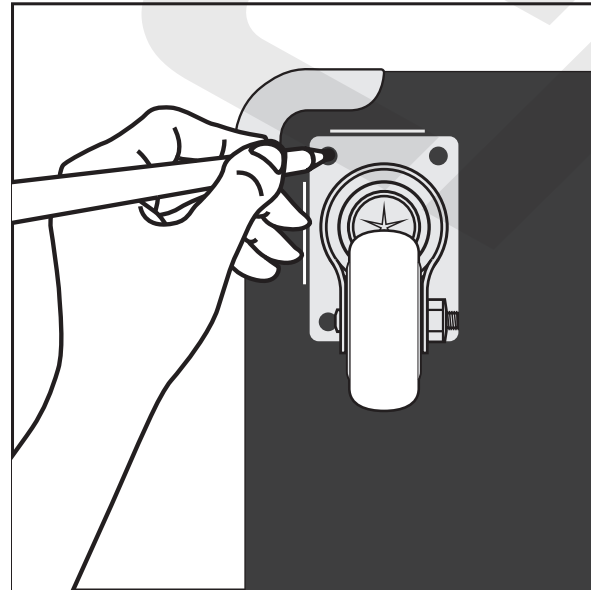

fig. C



fig. D

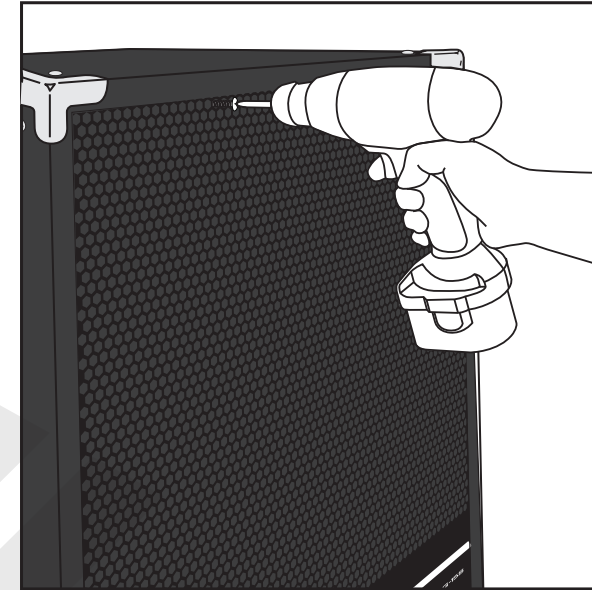

fig. E

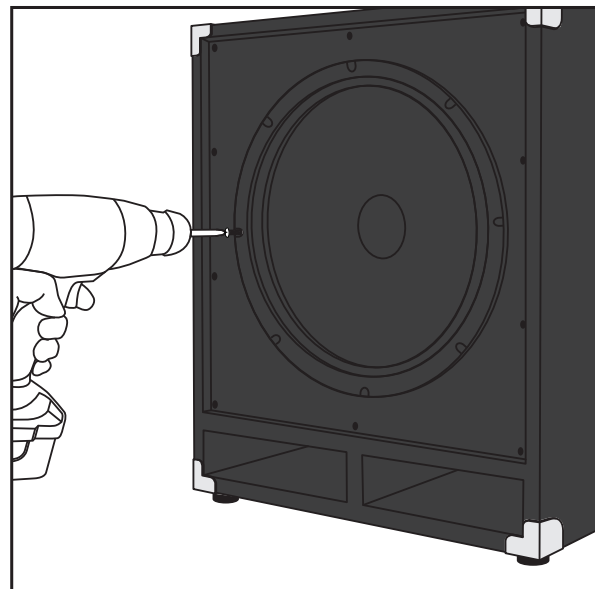
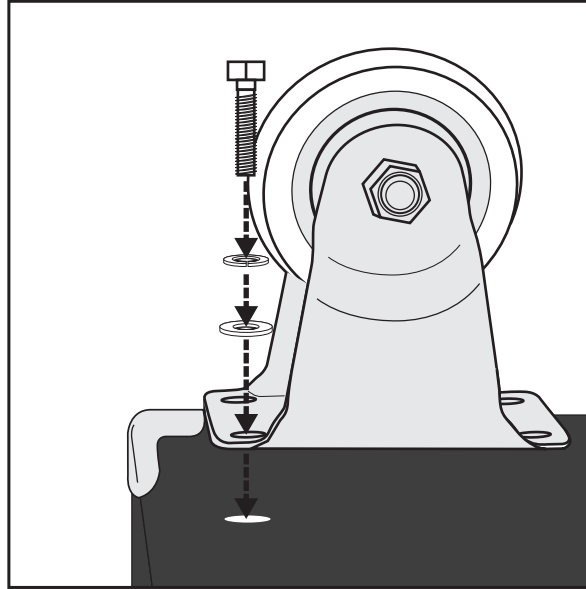

fig. F



fig. G



Scan the QR code or go to rockvillesupport.com/wh4 to access how-to video(s), the owner's manual, and other important information you may need to get the most out of your item.